

# Ori

## 1-SEATER MODULE

Ori is a decorative, modular sofa system in the interface between home and office. By combining form and function, Ori meets the need for well-designed and comfortable furniture in tomorrow's office.

Buildable sofa modules to create seating units for different types of tasks such as focused work or meetings.

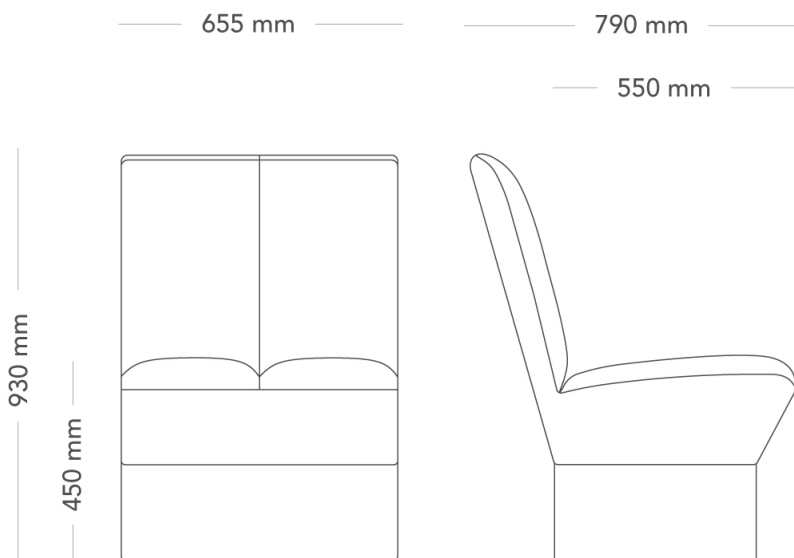

MODEL	Modular sofa system	
ACCESSORIES	<ul style="list-style-type: none"> <li>– Electrical accessories</li> <li>– Table</li> <li>– Adjustable feet</li> <li>– Cushion</li> </ul>	
DETAILS	– Different fabrics can be specified on the plinth and seat. The seating modules can easily be re-arranged into other setups and more modules can be added as needed.	
CONSTRUCTION	Frame and plinth consisting of plywood, solid wood, OSB board and MDF. Fixed plastic feet. Steel fittings connecting seat and back. Connecting fitting made of lacquered steel wire. Molded PUR-foam parts. Sewn textile upholstery. Adjustable steel feet with plastic bottom as option. Sofa table as option; lacquered steel frame, table top in MDF with veneered surface, lacquered full-radius beveled edge. Optional cushion, textile case with polyester padding.	
DIMENSIONS	Height: 930 mm Depth: 790 mm Sit depth: 550 mm	Width: 655 mm Seat height: 450 mm
WEIGHT	31.0 kg	
TESTED	EN 1335 level 1	

---

GUARANTEE

5 years

---

# Ori

## 2-SEATER MODULE

Ori is a decorative, modular sofa system in the interface between home and office. By combining form and function, Ori meets the need for well-designed and comfortable furniture in tomorrow's office.

Buildable sofa modules to create seating units for different types of tasks such as focused work or meetings.

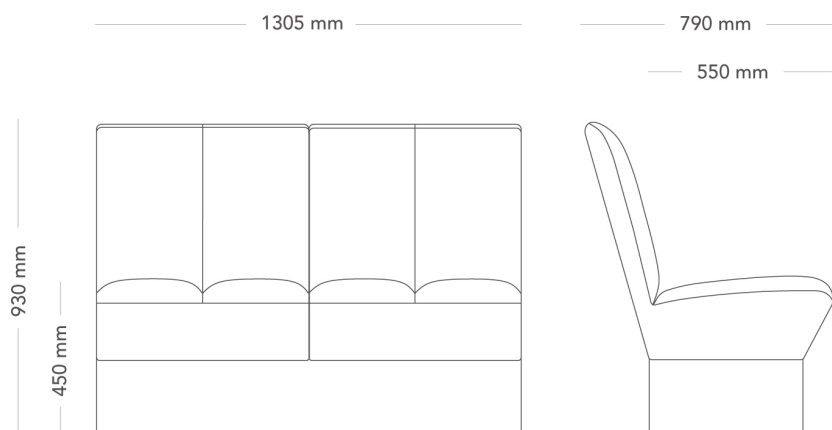

MODEL	Modular sofa system	
ACCESSORIES	<ul style="list-style-type: none"> <li>– Electrical accessories</li> <li>– Table</li> <li>– Adjustable feet</li> <li>– Cushion</li> </ul>	
DETAILS	– Different fabrics can be specified on the plinth and seat. The seating modules can easily be re-arranged into other setups and more modules can be added as needed.	
CONSTRUCTION	Frame and plinth consisting of plywood, solid wood, OSB board and MDF. Fixed plastic feet. Steel fittings connecting seat and back. Connecting fitting made of lacquered steel wire. Molded PUR-foam parts. Sewn textile upholstery. Adjustable steel feet with plastic bottom as option. Sofa table as option; lacquered steel frame, table top in MDF with veneered surface, lacquered full-radius beveled edge. Optional cushion, textile case with polyester padding.	
DIMENSIONS	Height: 930 mm Depth: 790 mm Sit depth: 550 mm	Width: 1305 mm Seat height: 450 mm
WEIGHT	57.7 kg	
TESTED	EN 1335 level 1	

---

GUARANTEE

5 years

---

# Ori

## 2-SEATER MODULE

Ori is a decorative, modular sofa system in the interface between home and office. By combining form and function, Ori meets the need for well-designed and comfortable furniture in tomorrow's office.

Buildable sofa modules to create seating units for different types of tasks such as focused work or meetings.

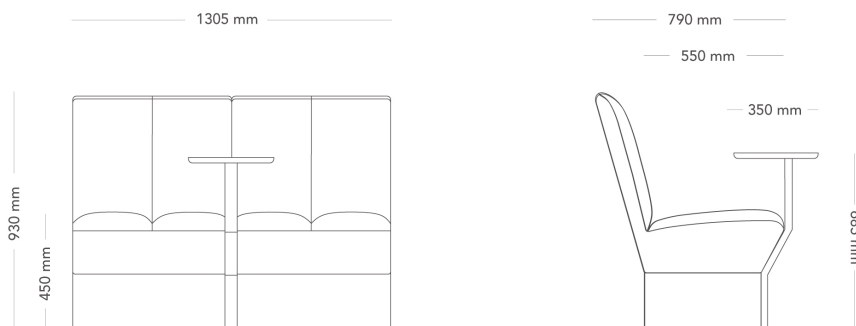

MODEL	Modular sofa system	
ACCESSORIES	<ul style="list-style-type: none"> <li>– Electrical accessories</li> <li>– Table</li> <li>– Adjustable feet</li> <li>– Cushion</li> </ul>	
DETAILS	– Different fabrics can be specified on the plinth and seat. The seating modules can easily be re-arranged into other setups and more modules can be added as needed.	
CONSTRUCTION	Frame and plinth consisting of plywood, solid wood, OSB board and MDF. Fixed plastic feet. Steel fittings connecting seat and back. Connecting fitting made of lacquered steel wire. Molded PUR-foam parts. Sewn textile upholstery. Adjustable steel feet with plastic bottom as option. Sofa table as option; lacquered steel frame, table top in MDF with veneered surface, lacquered full-radius beveled edge. Optional cushion, textile case with polyester padding.	
DIMENSIONS	Height: 930 mm Depth: 790 mm Sit depth: 550 mm	Width: 1305 mm Seat height: 450 mm
WEIGHT	57.7 kg	
TESTED	EN 1335 level 1	

---

GUARANTEE

5 years

---

# Ori

## 3-SEATER MODULE

Ori is a decorative, modular sofa system in the interface between home and office. By combining form and function, Ori meets the need for well-designed and comfortable furniture in tomorrow's office.

Buildable sofa modules to create seating units for different types of tasks such as focused work or meetings.

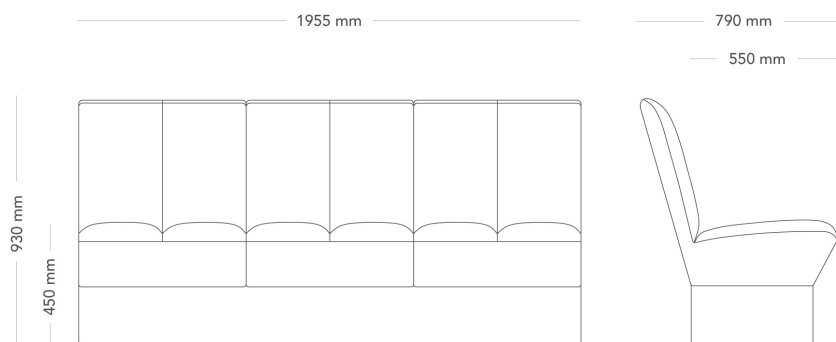

MODEL	Modular sofa system	
ACCESSORIES	<ul style="list-style-type: none"> <li>– Electrical accessories</li> <li>– Table</li> <li>– Adjustable feet</li> <li>– Cushion</li> </ul>	
DETAILS	– Different fabrics can be specified on the plinth and seat. The seating modules can easily be re-arranged into other setups and more modules can be added as needed.	
CONSTRUCTION	Frame and plinth consisting of plywood, solid wood, OSB board and MDF. Fixed plastic feet. Steel fittings connecting seat and back. Connecting fitting made of lacquered steel wire. Molded PUR-foam parts. Sewn textile upholstery. Adjustable steel feet with plastic bottom as option. Sofa table as option; lacquered steel frame, table top in MDF with veneered surface, lacquered full-radius beveled edge. Optional cushion, textile case with polyester padding.	
DIMENSIONS	Height: 930 mm Depth: 790 mm Sit depth: 550 mm	Width: 1955 mm Seat height: 450 mm
WEIGHT	86.4 kg	
TESTED	EN 1335 level 1	

---

GUARANTEE

5 years

---



# Ori

## 3-SEATER MODULE

Ori is a decorative, modular sofa system in the interface between home and office. By combining form and function, Ori meets the need for well-designed and comfortable furniture in tomorrow's office.

Buildable sofa modules to create seating units for different types of tasks such as focused work or meetings.

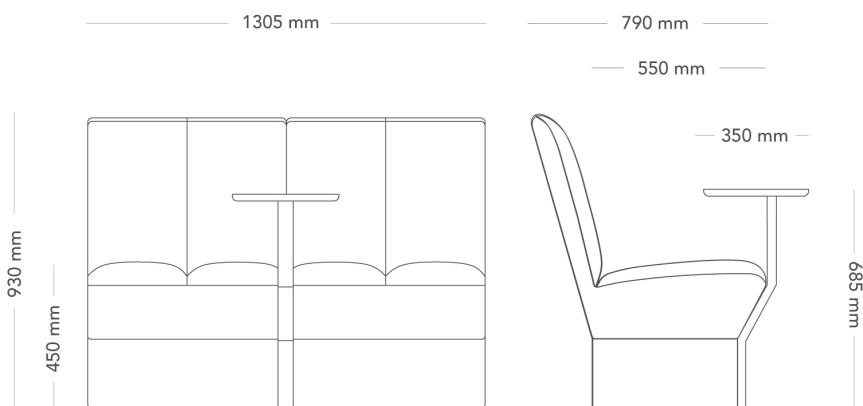

MODEL	Modular sofa system	
ACCESSORIES	<ul style="list-style-type: none"> <li>– Electrical accessories</li> <li>– Table</li> <li>– Adjustable feet</li> <li>– Cushion</li> </ul>	
DETAILS	– Different fabrics can be specified on the plinth and seat. The seating modules can easily be re-arranged into other setups and more modules can be added as needed.	
CONSTRUCTION	Frame and plinth consisting of plywood, solid wood, OSB board and MDF. Fixed plastic feet. Steel fittings connecting seat and back. Connecting fitting made of lacquered steel wire. Molded PUR-foam parts. Sewn textile upholstery. Adjustable steel feet with plastic bottom as option. Sofa table as option; lacquered steel frame, table top in MDF with veneered surface, lacquered full-radius beveled edge. Optional cushion, textile case with polyester padding.	
DIMENSIONS	Height: 930 mm Depth: 790 mm Sit depth: 550 mm	Width: 1955 mm Seat height: 450 mm
WEIGHT	86.4 kg	
TESTED	EN 1335 level 1	

---

GUARANTEE

5 years

---

# Ori

## 2-SEATER MODULE, ARMREST LEFT

Ori is a decorative, modular sofa system in the interface between home and office. By combining form and function, Ori meets the need for well-designed and comfortable furniture in tomorrow's office.

Buildable sofa modules to create seating units for different types of tasks such as focused work or meetings.

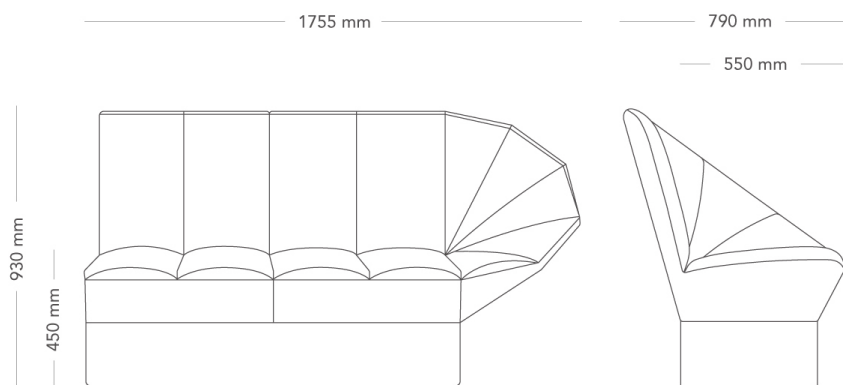

MODEL	Modular sofa system	
ACCESSORIES	<ul style="list-style-type: none"> <li>– Electrical accessories</li> <li>– Table</li> <li>– Adjustable feet</li> <li>– Cushion</li> </ul>	
DETAILS	– Different fabrics can be specified on the plinth and seat. The seating modules can easily be re-arranged into other setups and more modules can be added as needed.	
CONSTRUCTION	Frame and plinth consisting of plywood, solid wood, OSB board and MDF. Fixed plastic feet. Steel fittings connecting seat and back. Connecting fitting made of lacquered steel wire. Molded PUR-foam parts. Sewn textile upholstery. Adjustable steel feet with plastic bottom as option. Sofa table as option; lacquered steel frame, table top in MDF with veneered surface, lacquered full-radius beveled edge. Optional cushion, textile case with polyester padding.	
DIMENSIONS	Height: 930 mm Depth: 790 mm Sit depth: 550 mm	Width: 1755 mm Seat height: 450 mm
WEIGHT	64.9 kg	
TESTED	EN 1335 level 1	

---

GUARANTEE

5 years

---

# Ori

## 2-SEATER MODULE, ARMREST LEFT

Ori is a decorative, modular sofa system in the interface between home and office. By combining form and function, Ori meets the need for well-designed and comfortable furniture in tomorrow's office.

Buildable sofa modules to create seating units for different types of tasks such as focused work or meetings.

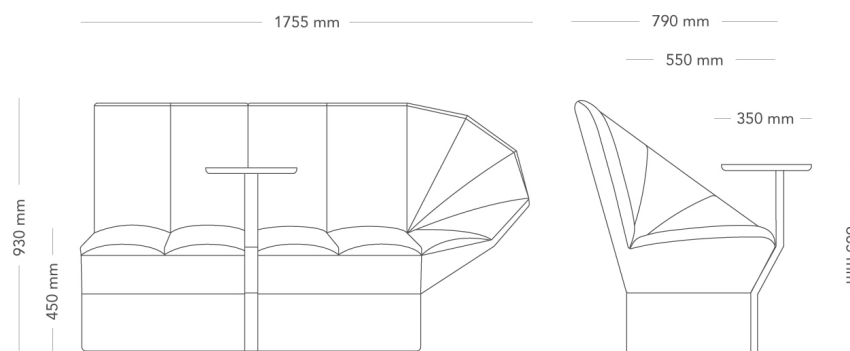

MODEL	Modular sofa system	
ACCESSORIES	<ul style="list-style-type: none"> <li>- Electrical accessories</li> <li>- Table</li> <li>- Adjustable feet</li> <li>- Cushion</li> </ul>	
DETAILS	- Different fabrics can be specified on the plinth and seat. The seating modules can easily be re-arranged into other setups and more modules can be added as needed.	
CONSTRUCTION	Frame and plinth consisting of plywood, solid wood, OSB board and MDF. Fixed plastic feet. Steel fittings connecting seat and back. Connecting fitting made of lacquered steel wire. Molded PUR-foam parts. Sewn textile upholstery. Adjustable steel feet with plastic bottom as option. Sofa table as option; lacquered steel frame, table top in MDF with veneered surface, lacquered full-radius beveled edge. Optional cushion, textile case with polyester padding.	
DIMENSIONS	Height: 930 mm Depth: 790 mm Sit depth: 550 mm	Width: 1755 mm Seat height: 450 mm
WEIGHT	64.9 kg	
TESTED	EN 1335 level 1	

---

GUARANTEE

5 years

---

# Ori

## 2-SEATER MODULE, ARMREST RIGHT

Ori is a decorative, modular sofa system in the interface between home and office. By combining form and function, Ori meets the need for well-designed and comfortable furniture in tomorrow's office.

Buildable sofa modules to create seating units for different types of tasks such as focused work or meetings.

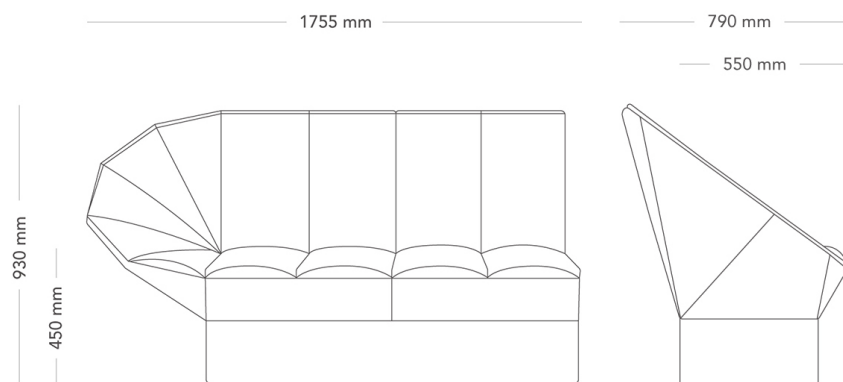

MODEL	Modular sofa system	
ACCESSORIES	<ul style="list-style-type: none"> <li>– Electrical accessories</li> <li>– Table</li> <li>– Adjustable feet</li> <li>– Cushion</li> </ul>	
DETAILS	– Different fabrics can be specified on the plinth and seat. The seating modules can easily be re-arranged into other setups and more modules can be added as needed.	
CONSTRUCTION	Frame and plinth consisting of plywood, solid wood, OSB board and MDF. Fixed plastic feet. Steel fittings connecting seat and back. Connecting fitting made of lacquered steel wire. Molded PUR-foam parts. Sewn textile upholstery. Adjustable steel feet with plastic bottom as option. Sofa table as option; lacquered steel frame, table top in MDF with veneered surface, lacquered full-radius beveled edge. Optional cushion, textile case with polyester padding.	
DIMENSIONS	Height: 930 mm Depth: 790 mm	Length: 1755 mm Seat height: 450 mm
WEIGHT	64.9 kg	
TESTED	EN 1335 level 1	
GUARANTEE	5 years	

# Ori

## 2-SEATER MODULE, ARMREST RIGHT

Ori is a decorative, modular sofa system in the interface between home and office. By combining form and function, Ori meets the need for well-designed and comfortable furniture in tomorrow's office.

Buildable sofa modules to create seating units for different types of tasks such as focused work or meetings.

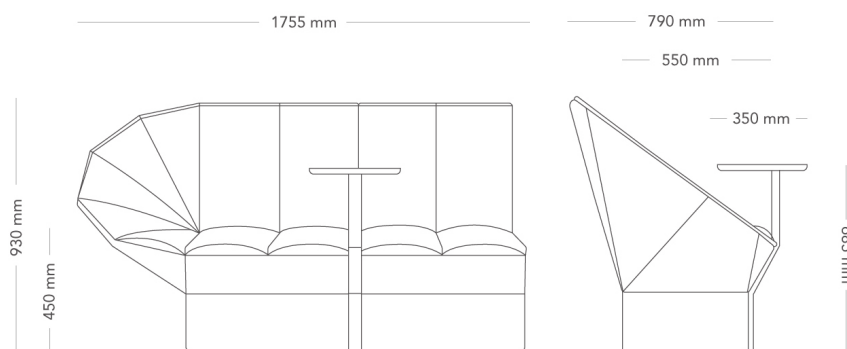

MODEL	Modular sofa system	
ACCESSORIES	<ul style="list-style-type: none"> <li>– Electrical accessories</li> <li>– Table</li> <li>– Adjustable feet</li> <li>– Cushion</li> </ul>	
DETAILS	– Different fabrics can be specified on the plinth and seat. The seating modules can easily be re-arranged into other setups and more modules can be added as needed.	
CONSTRUCTION	Frame and plinth consisting of plywood, solid wood, OSB board and MDF. Fixed plastic feet. Steel fittings connecting seat and back. Connecting fitting made of lacquered steel wire. Molded PUR-foam parts. Sewn textile upholstery. Adjustable steel feet with plastic bottom as option. Sofa table as option; lacquered steel frame, table top in MDF with veneered surface, lacquered full-radius beveled edge. Optional cushion, textile case with polyester padding.	
DIMENSIONS	Height: 930 mm Depth: 790 mm	Length: 1755 mm Seat height: 450 mm
WEIGHT	64.9 kg	
TESTED	EN 1335 level 1	
GUARANTEE	5 years	



# Ori

## OUTER CORNER MODULE

Ori is a decorative, modular sofa system in the interface between home and office. By combining form and function, Ori meets the need for well-designed and comfortable furniture in tomorrow's office.

Buildable sofa modules to create seating units for different types of tasks such as focused work or meetings.

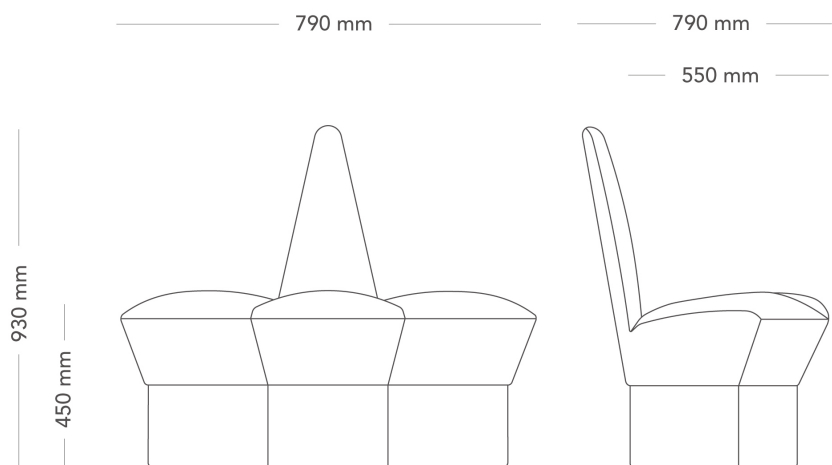

MODEL	Modular sofa system	
ACCESSORIES	<ul style="list-style-type: none"> <li>– Electrical accessories</li> <li>– Table</li> <li>– Adjustable feet</li> <li>– Cushion</li> </ul>	
DETAILS	– Different fabrics can be specified on the plinth and seat. The seating modules can easily be re-arranged into other setups and more modules can be added as needed.	
CONSTRUCTION	Frame and plinth consisting of plywood, solid wood, OSB board and MDF. Fixed plastic feet. Steel fittings connecting seat and back. Connecting fitting made of lacquered steel wire. Molded PUR-foam parts. Sewn textile upholstery. Adjustable steel feet with plastic bottom as option. Sofa table as option; lacquered steel frame, table top in MDF with veneered surface, lacquered full-radius beveled edge. Optional cushion, textile case with polyester padding.	
DIMENSIONS	Height: 930 mm Depth: 790 mm Sit depth: 550 mm	Width: 790 mm Seat height: 450 mm
WEIGHT	23.5 kg	
TESTED	EN 1335 level 1	

---

GUARANTEE

5 years

---

# Ori

## OUTER CORNER MODULE

Ori is a decorative, modular sofa system in the interface between home and office. By combining form and function, Ori meets the need for well-designed and comfortable furniture in tomorrow's office.

Buildable sofa modules to create seating units for different types of tasks such as focused work or meetings.

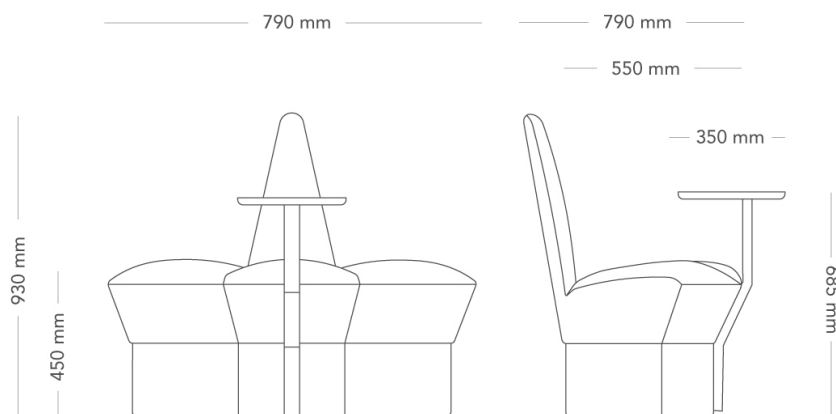

MODEL	Modular sofa system	
ACCESSORIES	<ul style="list-style-type: none"> <li>- Electrical accessories</li> <li>- Table</li> <li>- Adjustable feet</li> <li>- Cushion</li> </ul>	
DETAILS	- Different fabrics can be specified on the plinth and seat. The seating modules can easily be re-arranged into other setups and more modules can be added as needed.	
CONSTRUCTION	Frame and plinth consisting of plywood, solid wood, OSB board and MDF. Fixed plastic feet. Steel fittings connecting seat and back. Connecting fitting made of lacquered steel wire. Molded PUR-foam parts. Sewn textile upholstery. Adjustable steel feet with plastic bottom as option. Sofa table as option; lacquered steel frame, table top in MDF with veneered surface, lacquered full-radius beveled edge. Optional cushion, textile case with polyester padding.	
DIMENSIONS	Height: 930 mm Depth: 790 mm Sit depth: 550 mm	Width: 790 mm Seat height: 450 mm
WEIGHT	23.5 kg	
TESTED	EN 1335 level 1	

---

GUARANTEE

5 years

---

# Ori

## INNER CORNER MODULE

Ori is a decorative, modular sofa system in the interface between home and office. By combining form and function, Ori meets the need for well-designed and comfortable furniture in tomorrow's office.

Buildable sofa modules to create seating units for different types of tasks such as focused work or meetings.

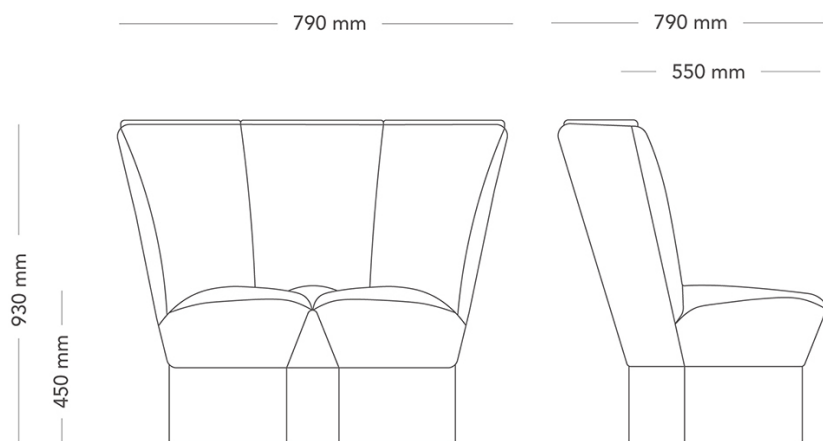

MODEL	Modular sofa system	
ACCESSORIES	<ul style="list-style-type: none"> <li>– Electrical accessories</li> <li>– Table</li> <li>– Adjustable feet</li> <li>– Cushion</li> </ul>	
DETAILS	– Different fabrics can be specified on the plinth and seat. The seating modules can easily be re-arranged into other setups and more modules can be added as needed.	
CONSTRUCTION	Frame and plinth consisting of plywood, solid wood, OSB board and MDF. Fixed plastic feet. Steel fittings connecting seat and back. Connecting fitting made of lacquered steel wire. Molded PUR-foam parts. Sewn textile upholstery. Adjustable steel feet with plastic bottom as option. Sofa table as option; lacquered steel frame, table top in MDF with veneered surface, lacquered full-radius beveled edge. Optional cushion, textile case with polyester padding.	
DIMENSIONS	Height: 930 mm Depth: 790 mm Sit depth: 550 mm	Width: 790 mm Seat height: 450 mm
WEIGHT	29.0 kg	
TESTED	EN 1335 level 1	

---

GUARANTEE

5 years

---